

eMH2 WALLBOX

MASTER WITH CHARGING CABLE

22 kW

The eMH2 Wallbox is our smart, attractively designed charging solution for domestic and semi-public applications. The translucent cover shows color backlit pictograms to indicate the current charging status. The integrated RFID module ensures fast and secure access. This eMH2 Master provides one Type 2 charging cable with a charging capacity of up to 22 kW. Our Wallboxes come with an integrated Type A RCD and DC fault current detection preinstalled. An additional Type B RCCB is therefore not required. The Wallbox eMH2 Master is prepared for use as a master unit and is suitable for multiple charge point applications.



General information

Model	eMH2
Model number	2W2241
EAN number	4011721176802
Commodity code	85371091
Packaging unit (PU)	1 unit
Packaging (dimensions HxWxD)	740 x 380 x 217 mm
Components included	Wallbox, printed quick reference guide, drilling template, mounting kit, 2 keys

Input/mains supply

Power supply	max. 5 x 16 mm ²
Rated voltage	230/400 V (3-phase)
Rated current	32 A
Rated frequency	50 Hz
Upstream fuse	MCB, C, max. 32 A
Terminal block	Direct connection to RCD PE to terminal block

Output/vehicle connection

Connection system	Single charging cable with Type 2 connector in acc. with IEC62196-2, ca. 6.35 m
Output voltage	230/400 V
Max. charging current	32 A
Maximum output	22 kW

Protection/integrated components

RCCB	RCD, Type A, 30 mA
DC fault current detection	electronic, $I_{\Delta n \text{ d.c.}} \geq 6 \text{ mA}$
Energy meter	MID approved (displayed in side window)
Load switching	Contactor, 4-pole
Welding detection	Contactor welding trips RCD
Temperature monitoring	internal, charging current reduction or shut down

Charging monitor/status indicators

Charge controller	EVCC2
Communication	in acc. with IEC 61851-1 Mode 3
Operating status indicator	LED
Error display	LED
RFID	ISO14443A/B, 4-byte/7-byte UID only
Communication EVSE	RS485, bus/master
Backend communication	OCPP 1.6 via LAN or LTE/WIFI (optional)

Standards/guidelines

IEC 61851-1
IEC 61439-7
IEC 62196-1
IEC 62196-2

Operating conditions

Storage temperature	-30 to 85°C
Operating temperature	-30 to 40°C
Relative humidity	5 to 95% - no condensation
Class of protection	I
Overvoltage category	III
Degree of pollution	3
Degree of protection (housing)	IP54
Impact strength	IK08
Maximum elevation	$\leq 2,000 \text{ m AMSL}$
Power dissipation	n/a

Housing

Type	Wall-mounted housing (can be used for cable storage)
Fixing type	Wall bracket (mounting kit provided)
Material (housing)	Plastic
Housing color	black, RAL9011
Material (cover)	Plastic
Cover color	black, translucent
Locking mechanism	Lockable cover with safety screw
Dimensions (HxWxD)	437 x 328 x 170 mm
Weight (net)	approx. 10 kg
Weight (gross)	approx. 12 kg

Optional accessories

see website at www.abl.de

Dimensioned drawing

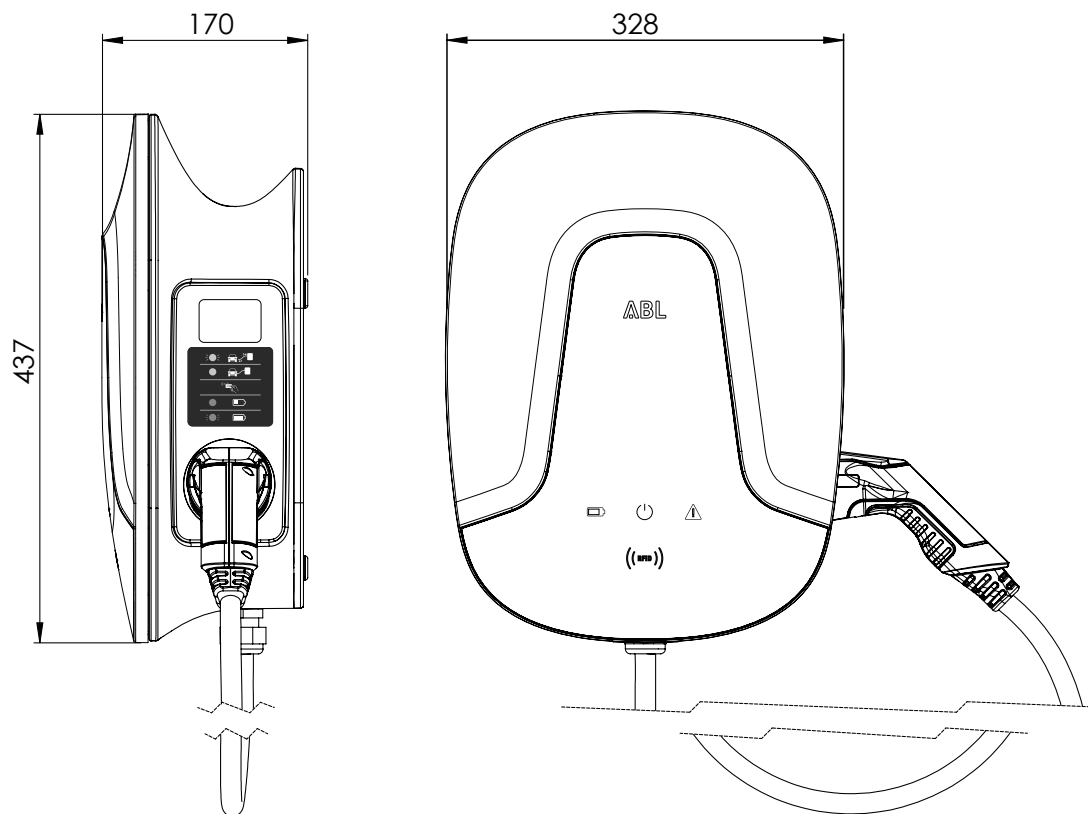

Subject to change: All features, specifications and other information are subject to change without notice.